



STONER

Model S-22H

PRODUCT DESCRIPTION

Stoners are recommended for efficient two-way separations of small amounts of heavy material from sized dry granular mixtures where the density difference between the light and heavy fraction is approximately 1.5:1 or more.

The S-22H, smallest of the Sutton Stoners, is frequently used to finish a concentrated heavy reject fraction from a Sutton Fluidized-Bed Separator to prevent any loss of product with rejects.

Capacities of the S-22H Stoner range up to 2 tons per hour, depending upon product size and density. Because different products require different deck cover materials on the separating surface, many varieties of woven wire, perforated metal and cloth deck covers are available to assure the best separation possible. Typical applications include:

Agricultural Removal of:

Product-size stones, glass and non-magnetic metals (which cannot be removed by screening) from wheat, corn, peanuts, beans, seeds and coffee beans, mudballs from ground-harvested almonds, unexpanded from "puffed" food products, such as puffed wheat, puffed rice, etc.

Industrial Removal of:

Copper from aluminum granules, "matchsticks" from wood flakes, metallic prills from crushed slag, unexpanded from expanded vermiculite following expansion furnaces, contaminating nodular iron pyrites from ground clay for brick and tile, "core" from kiln-burned lime.

HOW THE S-22H WORKS

The material is introduced onto a flat porous deck, sloped in one direction, and vibrated with a straight-line reciprocating motion. Low-pressure air, blown upward through the deck, fluidizes and stratifies the material according to differences in the terminal velocity of particles.

Heavy particles sink to the bottom of the stratified bed and are conveyed toward the high or "heavy" end by the deck's vibration. Narrowing towards the heavy discharge end, the deck's configuration concentrates the reject discharge and retains an inventory of heavy material to prevent product from being discharged with the rejects. Light particles, lifted by the fluidizing air, float downslope toward the light-end discharge.





STONER

Model S-22H

S-22H DESIGN FEATURES

FORCED AIR SUPPLY - Essential for the development of maximum capacity in any stoner.

QUICK RELEASE BANKING RAIL AND SLIDE-OUT DECK - Provide complete and easy access for cleaning or inspection.

SELF-BALANCING INERTIA DRIVE - Absorbs inertia forces for smooth operation. Drive and motor are fully enclosed.

DECK SLOPE AND AIR ADJUSTMENTS - Precise adjustment for positive, sensitive control of deck slope and air flow.

AIR INTAKE FILTER HOUSING - Independent of main unit and equipped with easy-to-clean filter panels.

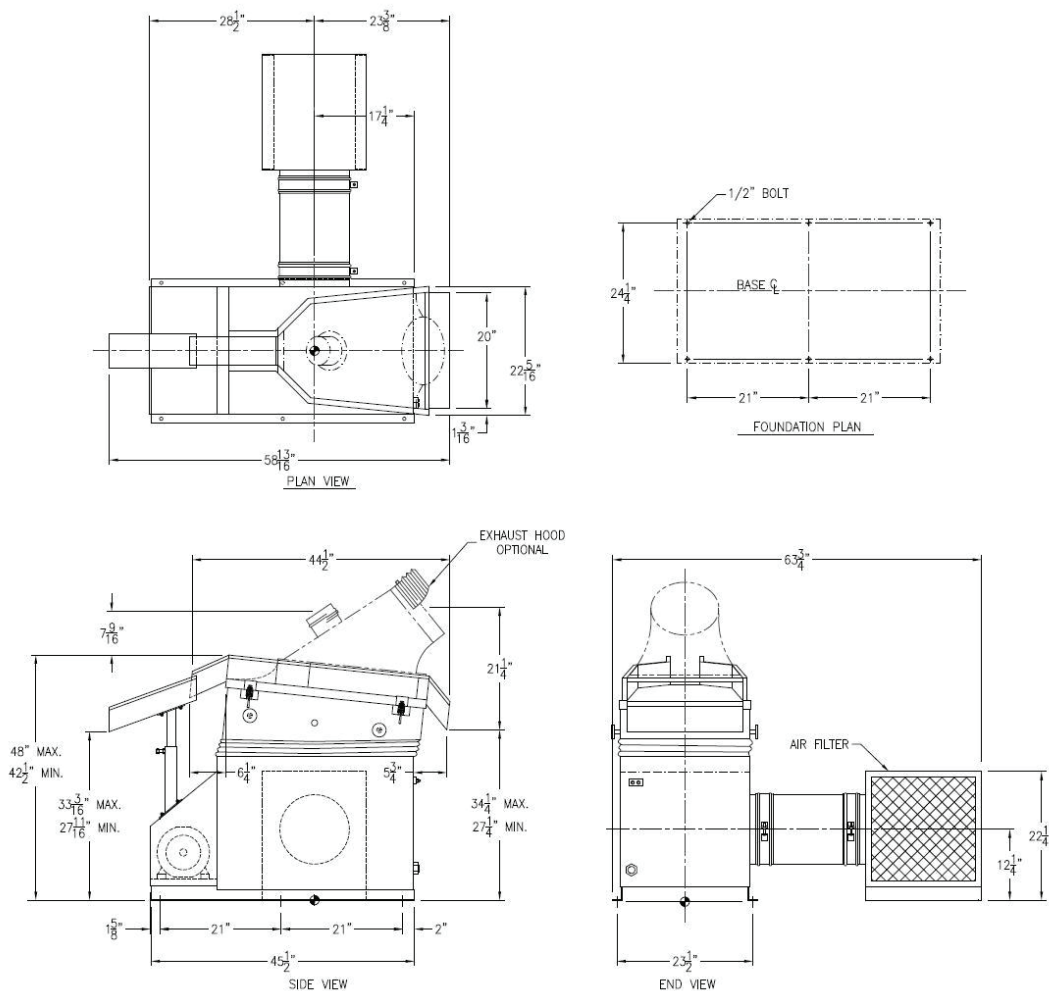

OPTIONAL FEATURES

SANITARY CONSTRUCTION - Contact surfaces with special epoxy finish or stainless steel for food or drug processing operations.

FIBERGLASS EXHAUST HOOD - Encloses the separation chamber for dust control. Exhaust blower required to provide suction air for units with exhaust hood. Matched exhaust system components and dust collectors are available to meet environmental requirements.



Triple/S Dynamics, Inc.
1031 S. Haskell Avenue Dallas, TX 75223
Ph. 214-828-8600 800-527-2116 www.sssdynamics.com