

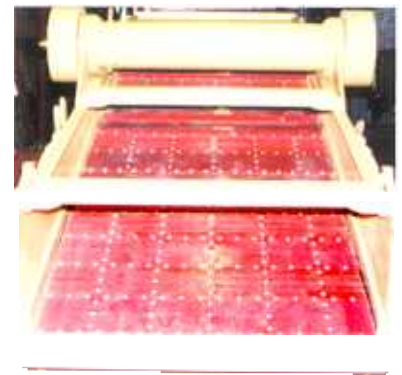

Screening Strategies  
By Triple/S Dynamics

# Overstrom<sup>®</sup> High-Speed Vibrating Screens



## **TRIPLE/S DYNAMICS-OVERSTROM®**

The origins of the Screening Strategies<sup>SM</sup> Division of Triple/S Dynamics, Inc., make us the most experienced name in screening technology. In 1891, Gustave Overstrom, one of our founders and a professor of mining engineering at the University of Utah, started an engineering business designing mining machinery. Overstrom, inventor of the high-speed two-bearing inclined vibrating screen, licensed many of his patents to early manufacturers of industrial and mining machinery.

Today, **OVERSTROM®** screening equipment is offered in five different basic designs, each with performance characteristics and mechanical features to match its intended uses. There are vibrating screens and rotary screens. The vibrating screens are classed as high-speed or slow-speed, and the high-speed screens are further divided into inclined and horizontal designs. Rotary screens are custom-designed units for applications that call for their special properties, such as the Rotascreen for screening solid waste.

Only the high-speed vibrating screens will be covered in this catalog: inclined circle-throw, horizontal straight-line, and variations on these basic designs. In all cases, their vibrations are inertially generated by unbalanced rotors, V-belt driven from an electric motor. Spring suspension systems isolate 85 to 95% of the inertia force from supporting bases or framing.

In the inclined screen, a single rotor generates vibratory motion in the vertical plane. This motion may be circular or elliptical, depending on where the rotor is mounted with respect to the machine's center of gravity. The material being screened moves over the downward-sloping surface by gravity, assisted by the vibration.

Two unbalanced rotors, made to rotate in opposite directions by coupling gears, generate the straight-line pitching motion required to move material over the surface of the horizontal screen.

## **VIBRATING SCREENS ARE NOT ALL THE SAME**

High-speed vibrating screens may be distinguished from other types, such as shaking or gyratory screens, in two respects: (1) there is a strong component of motion perpendicular to the plane of the screen surface; and, (2) the peak accelerations associated with the motion, either circular or reciprocating, typically fall in the range of four to six times the acceleration of gravity (4-6 g's).

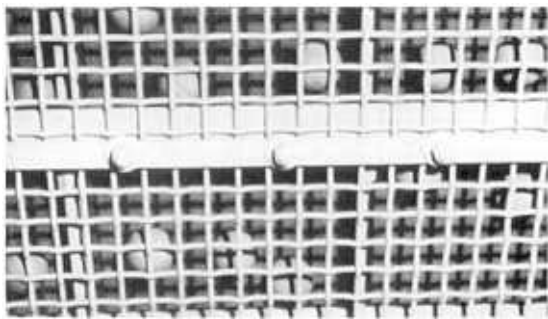

## **BALL DECKS FOR SCREENING DRY MATERIALS**

Natural gum rubber balls, confined in compartments beneath each screen surface, bounce between the support screen and the screen cloth, dislodging dry angular particles wedged within the sizing screen apertures. Ball decks can be provided on all models of vibrating screens with screen cloth as fine as 60 mesh. For elevated temperature applications, or when screening oily materials that may attack natural rubber, spring steel wire-wound balls can be substituted.

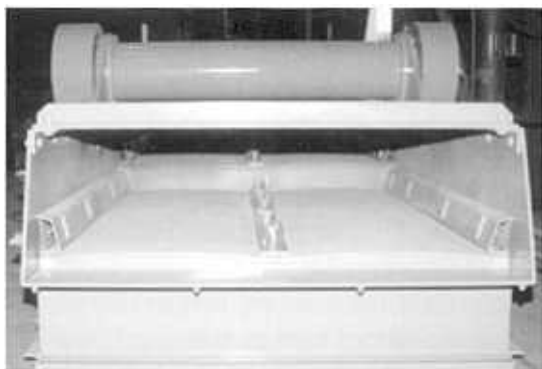

## **STEP DECKS FOR SCREENING DEEP OVER-SIZE LOADS**

When screens have to contend with deep oversize loads, stepped decks, such as the double-crowned single-step design shown, enhance screening efficiency, assuring maximum fines removal. The step design interrupts the oversize bed, giving trapped undersize particles a “second chance” to find the screen apertures. One or more steps can be provided on any or all decks of vibrating screens.



## **FLAT PLATE DECKS FOR INTERMEDIATE SCALPING**

Abrasion resistant steel plate screen decks, protected with manganese skid bars, may be used for intermediate scalping operations where large oversize rocks or chunks are handled, such as in pit-run aggregate screening applications. Outlasting high carbon steel wire, these plates may be constructed to any desired thickness, in any HSLA steel plate.



## **GRIZZLY BARS FOR HEAVY-DUTY SCALPING**

Grizzly bars are used for heavy-duty applications such as scalping mine, pit, or quarry-run rock to bypass fines and dirt around the primary crusher. Bars may be spaced down to approximately 1 1/2” minimum, and constructed as individually removable manganese steel castings or fabricated steel “T”-bars, mounted as a removable one-piece assembly.

Cast grizzly bars are shaped like inverted wedges. The gap between adjacent bars increases from top to bottom to prevent blinding caused by material wedging between the bars. Both cast bars and welded grids diverge slightly from feed to discharge. This prevents near size lumps from wedging as they travel down the screen.

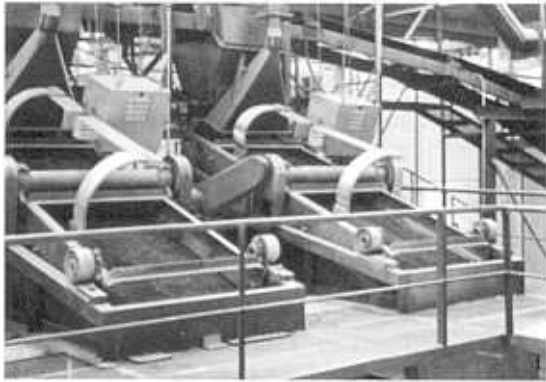

**ELECTRIC HEAT FOR SCREENING DAMP, STICKY MATERIAL**

Electric heat is the most effective protection against blinding when screening damp; sticky material, such as clay and shale, on 3/4" openings or less. Heating transformers, consuming from 2 to 3 KVA per foot of screen length, can be used with any screen cloth weighing less than about 1.5 lbs. per square foot. The current flows at a low voltage (1-12) and a high amperage to produce temperatures on the screen wires ranging from 80-150°F. This heat is not intended to dry the material being screened, but only to dry the interface between the wire and adhering clay sufficiently to break the adhesive bond holding the clay to the wire. The screen vibration does the rest.

Because the low voltage used is not more than that of an auto battery, screen frames and cloth can be handled even with the power on.

**WATER SPRAY BARS FOR SCREENING DAMP MATERIALS**



Water spray bars with fan-type nozzles stop buildup of damp fines or clays which cause blinding due to bridging. Sprays are essential when screening through 1/8" or smaller apertures damp bank-run sand and gravel, even if not required by product specifications. If the material contains clay, sprays should deliver about 8 gpm of water per tph of feed to the screen. If no clay is present, the water volume can be reduced to 4-5 gpm per tph.

Depending upon the application, sprays can be applied on the top deck only, or on all decks. If the screen openings on the upper deck are larger than 1/2", the deck below may not require extra water.

When screen openings are below about 1/2", well-designed spray systems will increase screening capacity 1 1/2 to 3 times the dry capacity ratings. The amount of the increase will depend upon the screen aperture and size gradation of the sand.

**REPULPING TROUGHS FOR DEWATERING SCREENS**

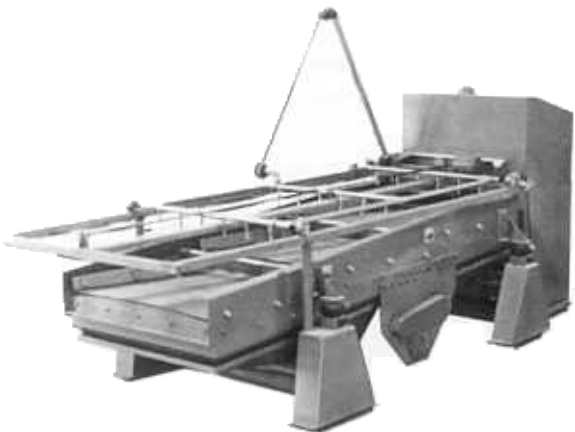

For wet screening of fine material, repulping troughs are often used with stationary spray bars to prevent blinding, and to protect the screen from rapid wear at the point of direct spray impingement.

Designed to wash grit from a previously scalped centrifuged sewage sludge, the straight-line horizontal unit pictured to the left is equipped with repulping troughs between three stepped screen panels. Instead of stationary spray bars, a system of traveling hot-water spray bars keeps the screen free of grease.

## IS IN THE DETAILS

The VIBRATOR SHAFT is machined from a tough, hardened alloy steel bar. Seal journals are protected with polished chrome sleeves.

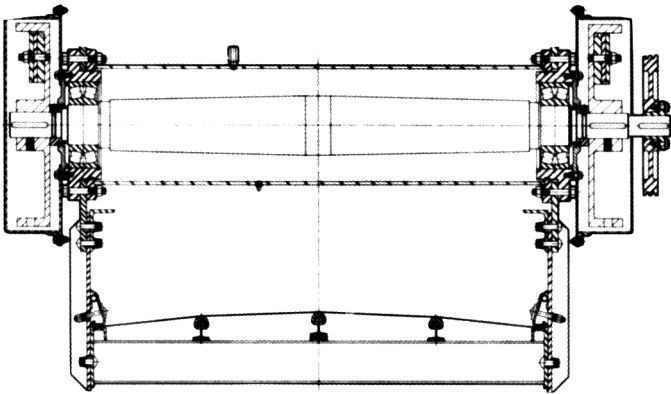

Two-Bearing Vibrator Unit Assembly

### STRAIGHT-LINE VIBRATOR UNIT FOR HORIZONTAL VIBRATING SCREENS

The STRAIGHT-LINE INERTIA DRIVE is the simple and dependable gear-coupled, contra-rotating, parallel twin unbalanced rotor enclosed module, V-belt driven from a single standard electric motor. The full-width assembly is bolted to the screen box, providing easy accessibility for maintenance or removal for shop repairs.

The four SPHERICAL ROLLER BEARINGS are the same as those used in the **OVERSTROM** two-bearing single-rotor vibrator units. All four are press-fit to individual bearing housings, and slip-fit on the shaft journal. Inner oil seals keep the rotor housing dry. The two bearings on the gear side are splash-lubricated within the gear case. On the opposite side, one rotor shaft projects through a sealed end cover to mount the driving V-belt sheave. As in the single-rotor design, a labyrinth outer shield protects the inner elastomeric seal from dirt and moisture intrusion.

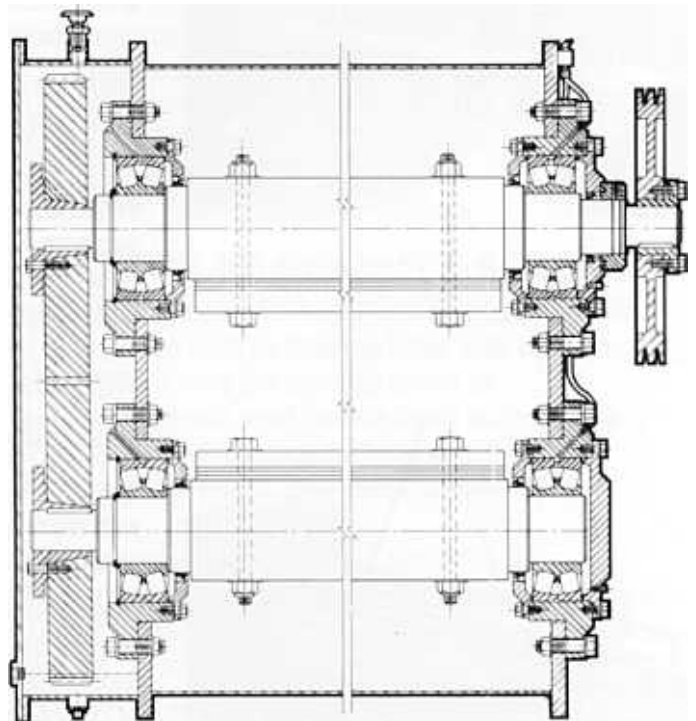

Straight-Line Vibrator Unit Assembly

## **THE SCREEN BOX**

Construction of the screen box is the same for both horizontal and inclined high-speed vibrating screens.

The SIDE PLATES are constructed of one-piece steel plate with thickness and hardness appropriate to the size and duty of the machine. Stiffening flanges are structural angle shapes, bolted to the top edge of the plate.

The DECK FRAME WELDMENT of structural shapes, selected for best strength-weight ratio, supports the screen surface over rubber-cushioned manganese mine car rails. This establishes the correct crown uniformly over the full length of the deck panel and maintains it distortion-free over the entire life of the screening machine. (Self-cleaning ball decks are designed with rectangular bar rails instead of mine car rails.)

The neoprene RUBBER-RAIL CUSHION extrusions are shaped to fit the bulb of the rail tightly. They won't peel off when the screen cloth or plate is installed, as often happens with common channel sections over flat bar rails. Other cushion materials are available for elevated temperature applications.

The DECK FRAME WELDMENT is bolted in place between the side plates. This is the key to long fatigue-free life and relatively easy replacement should the frame eventually wear out in heavy-duty service with abrasive materials.

SCREEN CLOTH CHANGES, when required, are made easy by the unique, patented, stretcher bar lifter device that rotates the tensioning bar out of the screen edge hooks when bolt tension is released. Fine-mesh screens can be removed and replaced while the stretcher bars remain in place. Screens may be changed from either end of the screen box.

ISOLATION SPRINGS, supporting the vibrating assembly, are manufactured to exacting specifications. Chrome-vanadium bars are hot-formed and heat-treated, then shot peened and magnetic particle inspected to insure correct stiffness and long life. A heavy enamel dip coating protects the springs from corrosion in wet applications. Special low-stiffness rubber or pneumatic springs can be

substituted where required to minimize vibration transmission.

RESONANT ENERGY DAMPERS are used on the larger size units to limit overstroking when the vibrator coasts through resonance with the spring suspension during shutdown. Rubber absorbers or friction dampers limit amplitude buildup at resonance.

## **TWO-BEARING VIBRATOR UNIT FOR INCLINED VIBRATING SCREENS**

The ECCENTRICALLY-MOUNTED (OHV) overhead mounting, of the two kinds of vibrator mountings offered, provides the easiest access for maintenance or replacement. The entire assembly can be removed intact and taken to the shop for disassembly and repair in a clean environment more favorable to careful work and freedom from contamination.

CENTROIDALLY-MOUNTED VIBRATOR UNITS (CV) are rebuilt or repaired in place by changing the bearing housing cartridges, which can be individually removed from each side. The cartridges may then be taken to the shop for bearing and seal replacement

The heavy-duty straight-bore SPHERICAL ROLLER BEARINGS, specially designed for use in vibrating screens, in bore size from 75 to 200 mm are press fit in the bearing housing for a predetermined internal clearance. A close slip fit on the shaft journals makes replacement easy and extends bearing life by allowing the inner ring to rotate slowly with respect to the centrifugal load. Two smaller sizes, 50 and 65 mm, are mounted on tapered bearing journals to set the internal clearance, and slip-fit in the housings.

OIL BATH LUBRICATION is standard on all single-rotor high-speed vibrating screens. Bearings are protected from dirt and moisture intrusion by labyrinth outer seals that shield the elastomeric oil seals. Compared with grease lubrication, oil-bath lubricated bearings run cooler, require less attention, last longer and adapt better to temperature extremes.

## HORIZONTAL VIBRATING SCREENS

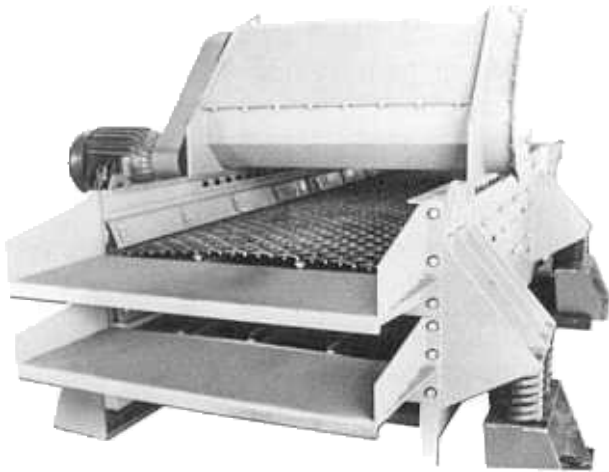

Horizontal High-Speed Vibrating Screen

Horizontal vibrating screens are available in the same sizes as the equivalent two-bearing inclined models. A pair of gear-coupled, parallel-shaft unbalanced rotors in an enclosed full-width vibrator module applies the straight-line inertia force that generates the reciprocating motion of the screen box. The module is mounted so that its line of action passes through the center of gravity of the screen box, which moves in a straight-line, reciprocating pitching motion that conveys as it screens (see diagram below). This contrasts with the circular motion of the inclined screen, which depends on its downward slope to move the retained material over the screen.

In both horizontal and inclined screens, the vertical component of the vibrating motion expands the over-size material bed to create extra voidage through which the undersize rapidly settles and finds its way to the screen openings. To control its tendency to produce a "landslide" effect, the inclined screen is limited to lower maximum amplitudes than the horizontal. The greater amplitude required to propel the retained material over a horizontal surface improves stratification, and because the material can't roll or slide on the level surface, the horizontal screen is generally considered to be more efficient than the inclined.

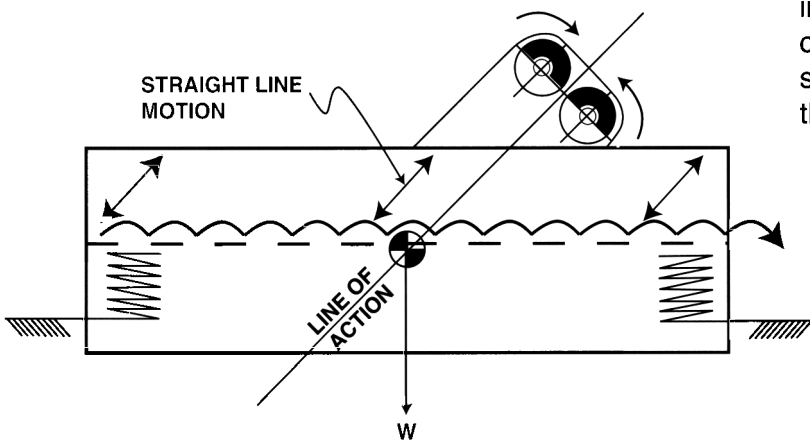

Horizontal Vibrating Screen (Straight-line Motion)

**OVERSTROM** high-Speed Vibrating Screens, designed for general-purpose wet or dry screening fall into one of two broad categories — the inclined (elliptical or circular motion) and the horizontal (straight-line motion).

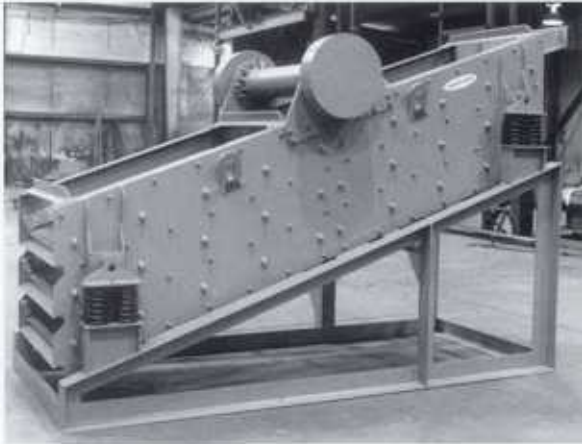

6' x 12' 3-Deck OHV Inclined Vibrating Screen

## INCLINED VIBRATING SCREENS

Inclined screens are vibrated by a single, two-bearing, unbalanced rotor mounted concentrically or eccentrically with respect to the centroidal axis of the screen (See diagrams below).

Overhead-mounted rotors, designated "OHV", generate a slightly rocking motion, as shown in the diagram. The forward-inclined ellipse at the feed end accelerates incoming material to promote initial screening while the slightly backward-inclined ellipse at the discharge retards the oversize travel rate to help in the final removal of near-size particles.



8' x 20' Model CV Single Deck Inclined Vibrating Screen.

Concentrically-mounted rotors generate a uniform circular motion over the length of the screen, from feed to discharge, moving oversize material smoothly at a uniform rate. Inclined screens with concentric rotor mountings, designated "CV", are less susceptible to blinding in coarse screening of acicular or "spikey" particle shapes than units with overhead mountings.

Inclined vibrating screens offer lowest cost per ton hour, and can handle heavy oversize burdens, at somewhat compromised precision in sizing compared with the horizontal. **OVERSTROM** inclined screens are made in sizes ranging from 2' x 4' to 10' x 24'. Speeds and amplitudes can be field-adjusted to optimize performance.

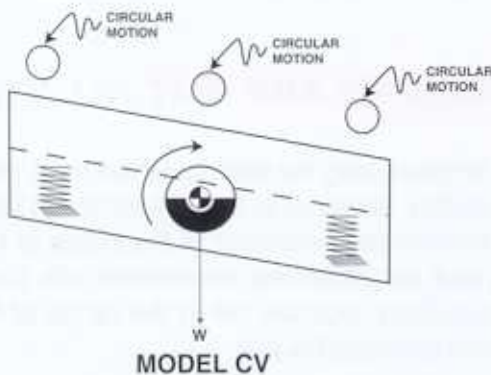

Concentric Rotor – Inclined Vibrating Screen (Uniform circular motion)

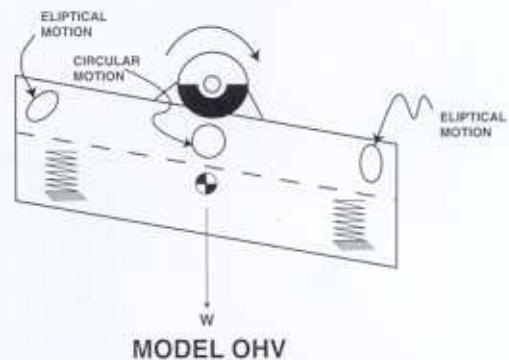

Eccentric Rotor – Inclined Vibrating Screen (Elliptical motion)

## VIBRATION ISOLATION

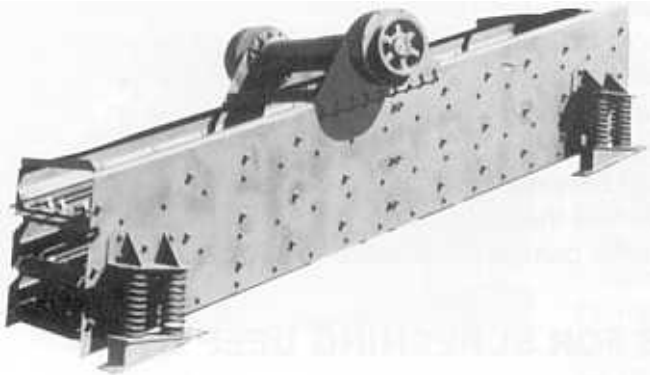

The inclined vibrating screen in standard open construction includes spring brackets for installation on customer's support beams or base.

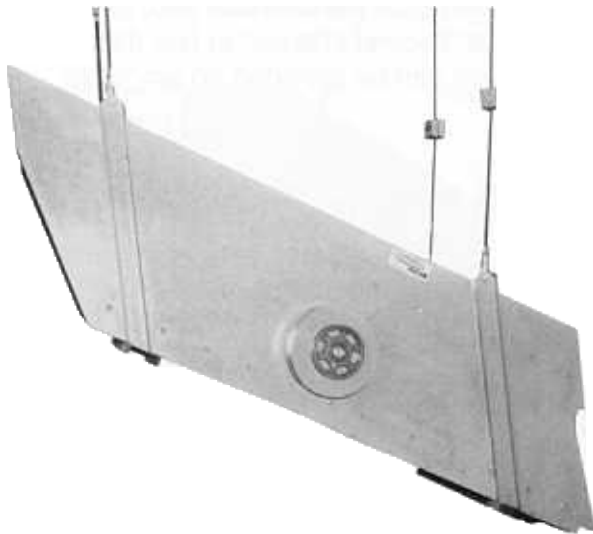

Standard open construction for cable suspension includes suspension cables, fittings and springs with brackets for mounting to the customer's overhead support beams.

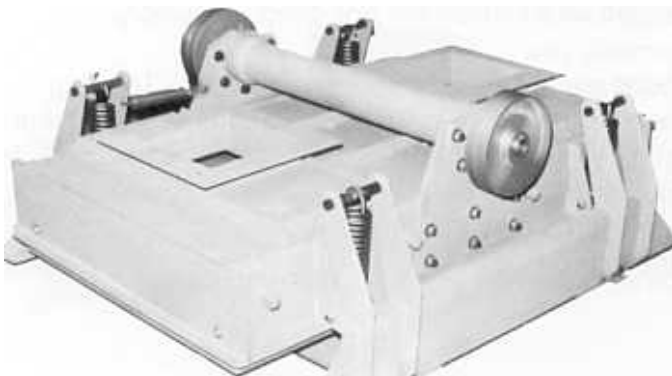

The basic inclined or horizontal inertia-driven screen is supplied with helical isolation springs and brackets for mounting to the customer's support beams or pedestals, or for cable suspension.

An optional rigid base frame is available for inclined vibrating screens. An optional skid base can be provided for horizontal vibrating screens. These mount from a level floor line and incorporate the isolation spring mounts as well as an automatic motor base. The base frame positions the screen at the optimum slope recommended for the proposed application.

Isolation of horizontal forces is somewhat better with the optional cable suspension than with base support and coil springs. Equivalent isolation efficiency can be obtained in base mounting with specially designed rubber compression springs. Smaller units can be suspended from extension springs for maximum isolation, when required. Extension spring suspensions allow large static deflection without loss of stability.

With a screening unit that operates at low amplitude and high frequency, vibration transmission through the suspension is imperceptible. These machines can safely be operated in close proximity with, or even mounted on, weigh scale hoppers.



Horizontal vibrating screen in standard open construction is furnished with isolation springs and brackets for mounting to the customer's support beams or pedestals. The "finger" screen shown (above) is used for length separations.

Extension spring suspension from the base frame gives the most efficient vibration isolation possible and permits mounting this powder scalping screen (left) directly on the user's scale weigh hopper.

## ENCLOSURES

The basic high-speed vibrating screen is of standard open construction, but can be furnished with either of two types of dust enclosure, stationary or integral. Stationary enclosures are recommended for heavy-duty applications such as the screening of abrasive materials that require wear liners in chutes and hoppers. Integral enclosures are recommended when serious abrasive wear is not anticipated. They are more convenient, occupy less space and cost less.

Stationary enclosures (Type "A") comprise a base frame with built-in two-piece bottom hopper made with a dust-tight stationary-to-vibrating sealing arrangement, and a stationary oversize chute assembly, hinged from the stationary base frame and sealed to the vibrating screen box. The oversize chute assembly swings upward to allow access to the screen cloth. The enclosure is completed with an integral feed hopper mounted to the screen box, and integral formed steel cover lids, mounted to the top flange of the screen box. An automatic motor bracket is included in the base frame structure.

In the integral dust enclosure (Type "B"), the stationary bottom hopper and oversize chute assemblies of the stationary enclosure are replaced with a formed bottom collecting pan attached to the screen box, and built-in discharge outlets for oversize. With feed box and formed steel cover lids secured to the screen box, the enclosure is dust-tight, and can be gasketed to contain gas pressure up to about 3 psi, or it can be designed to withstand still higher pressures.



**Stationary dust enclosure with hinged oversize chute in raised position for access to screen deck. Arrangement includes a base frame to level floor line with motor bracket. Sub-base bottom hopper for fines not shown.**

**Integral dust enclosure and support frame to level floor line. The base frame includes the motor mounting bracket and belt guard.**

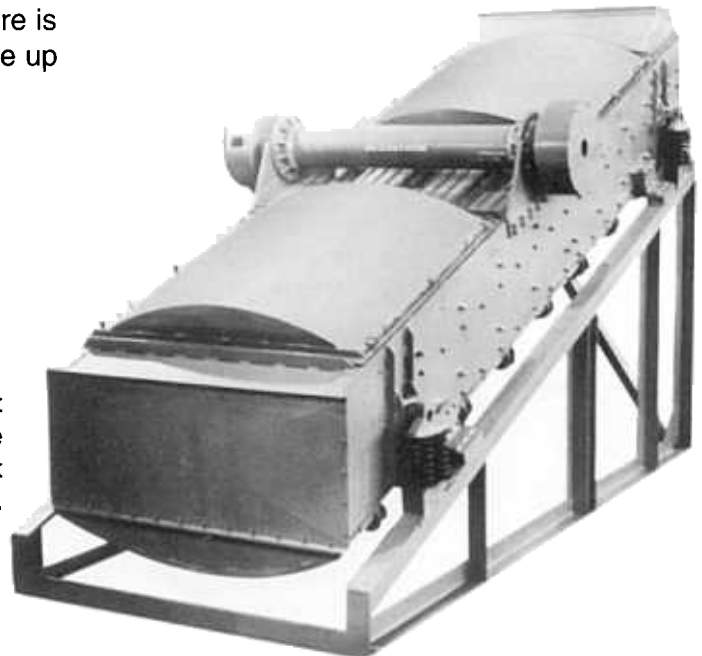

# SCREENS FOR GLOBAL INDUSTRY

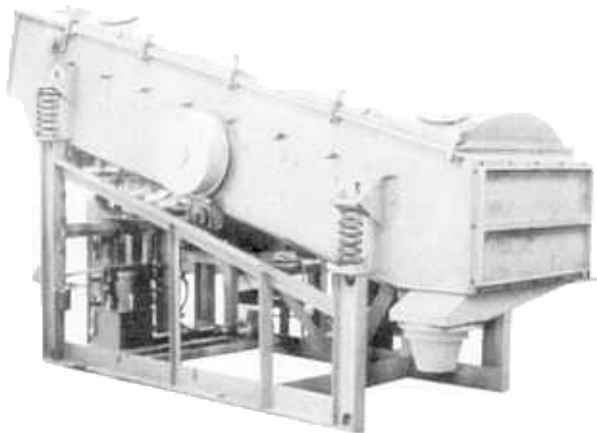

Special model CV inclined vibrating screen features a gas-tight enclosure and a circulating oil system with air/oil cooler for screening fly ash from hot dry scrubber filter media.

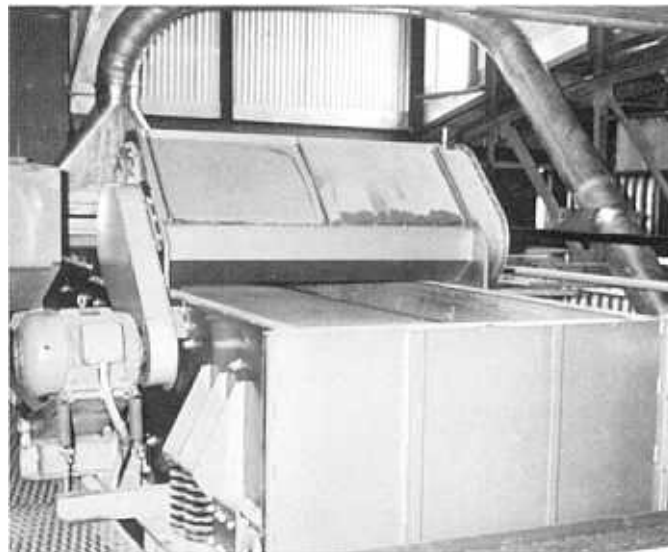

A 5' x 12' two-deck straight-line horizontal vibrating screen used for fine-mesh sizing of a mixture of granulated copper wire and insulation prior to air separation. The horizontal vibrating screen is preferred over the inclined screen for precision sizing.

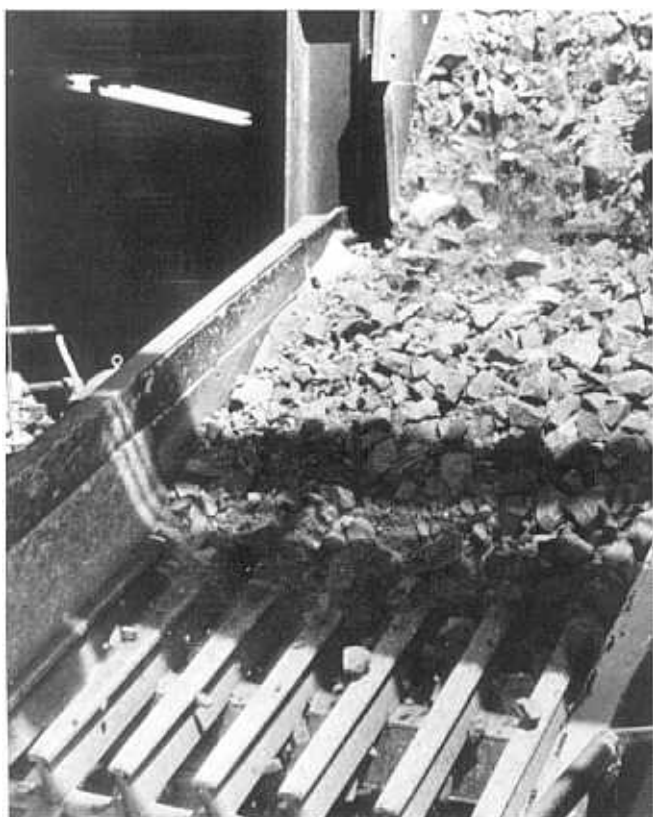

An inclined CV scalping screen with stepped "grizzly" bar deck bypasses undersize around the primary crusher in a hard-rock mine. The T-bar caps are tapered to prevent near-size blinding. This very heavy-duty machine was provided with circulating oil lubrication because of the dusty location and maintenance-free demands of the application.

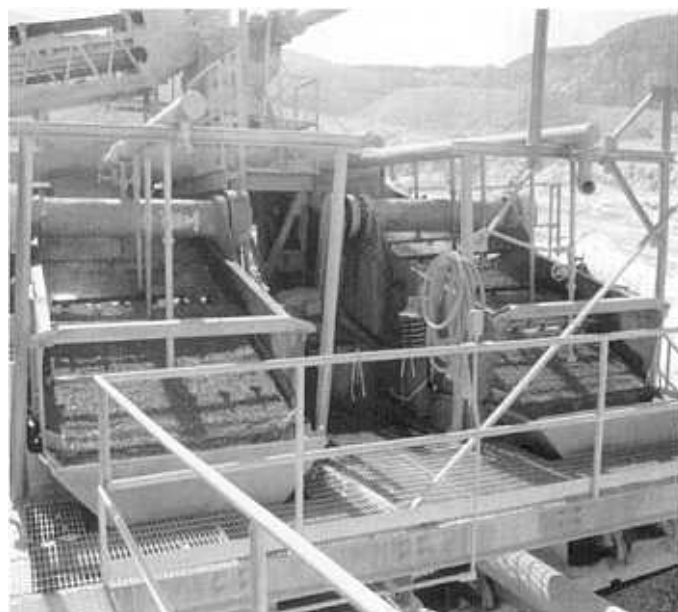

Washing silica sand through 0.65 x 12 mm Polydex™ urethane screen panels in a pair of 5'x12' OHV inclined vibrating screens.

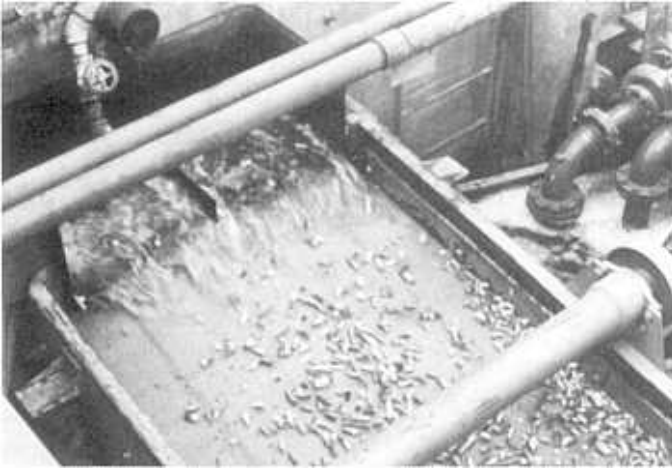

In a cannery, an OHV inclined vibrating screen separates waste solids from effluent water before discharge to a sewer or purification system.

In a peanut shelling plant, two 4' x 10' OHV inclined vibrating screens clean sand from 30 tph of as-received peanuts. The dust enclosures are stationary.

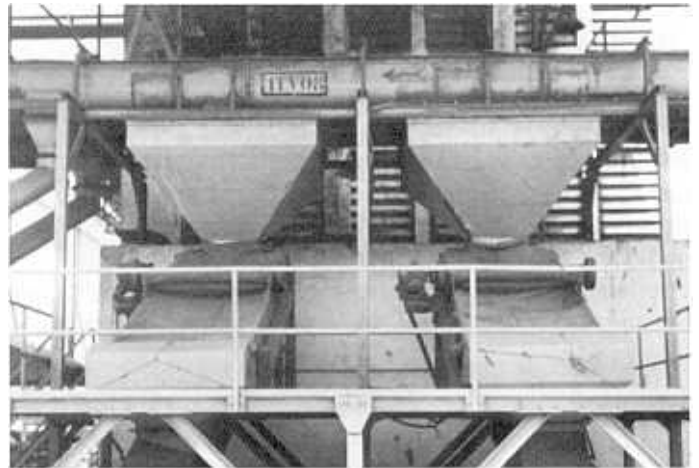

Screening fines from iron ore in a steel mill with 10 ft. x 24 ft. horizontal vibrating screens.

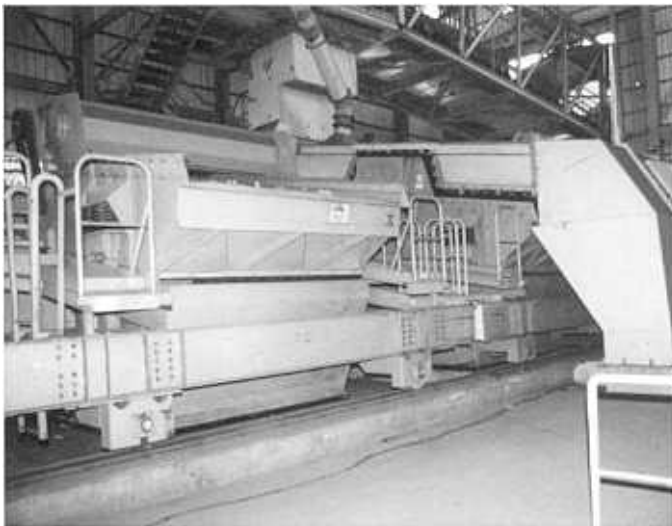

Overstrom Vibrating Screens can be equipped with a variety of proprietary polyurethane screen surfaces resistant to abrasion and blinding. Typical applications include crushed stone, sand, gravel, coal, feldspar, taconite, lime, and compost.

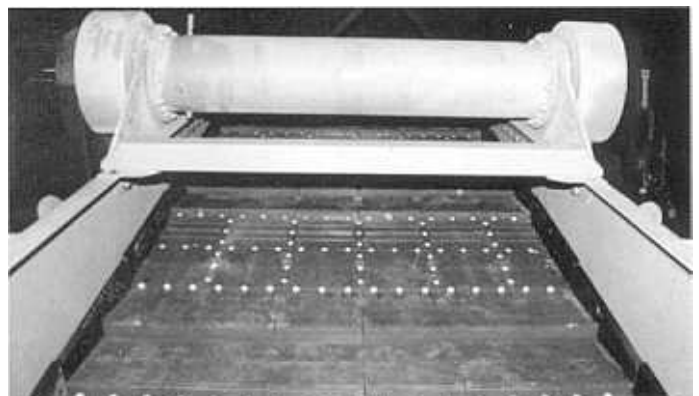

# SPECIAL PURPOSE SCREENS

## PORTABLE SCREENING PLANTS



A portable fixed-bed catalyst and support media screening plant, based on the straight-line horizontal vibrating screen, is readied for testing at the factory. Positioned at the reactor undergoing turnaround in the refinery, the plant discharges the separated catalyst pellets, fines and two sizes of support media. Airborne dust is aspirated and collected in a cyclone and bag filter.

Any screening unit can be supplied on a mobile chassis for portable operations in aggregate plants, refineries, strip mines or wherever mobility is a requirement.

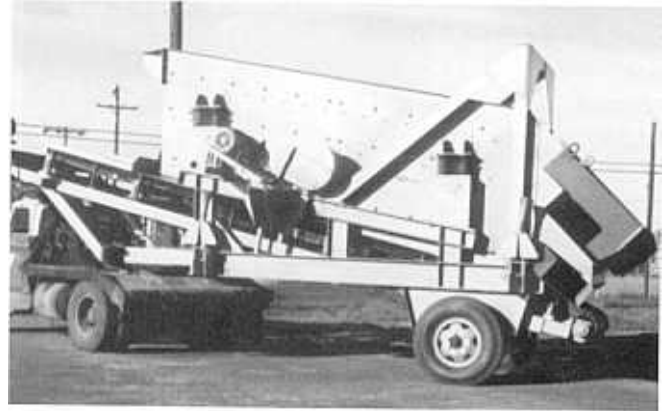

The three-deck, 5' x 12' unit pictured was supplied with feed hopper, discharge chutes, fines conveyor and gating arrangements for a variety of six blending combinations in the production of road construction aggregates from pit-run limestone.

## FOUNDRY SHAKEOUTS

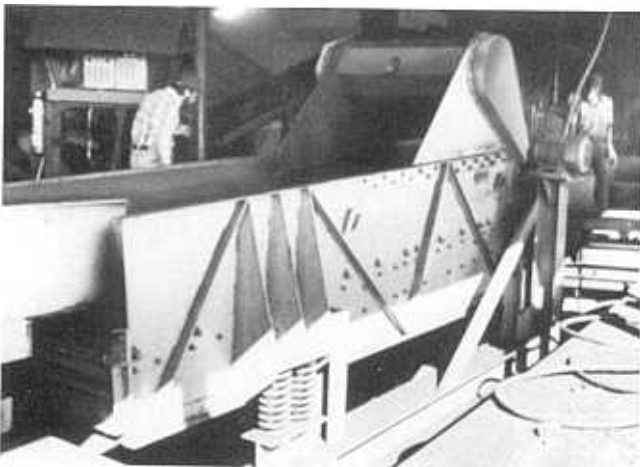

A straight-line horizontal vibrating shakeout screen separates molding sand from hot castings in a gray iron foundry. Rugged construction and high mechanical reliability are primary requirements in this application.

## INERTIA-DRIVEN VIBRATING FEEDERS

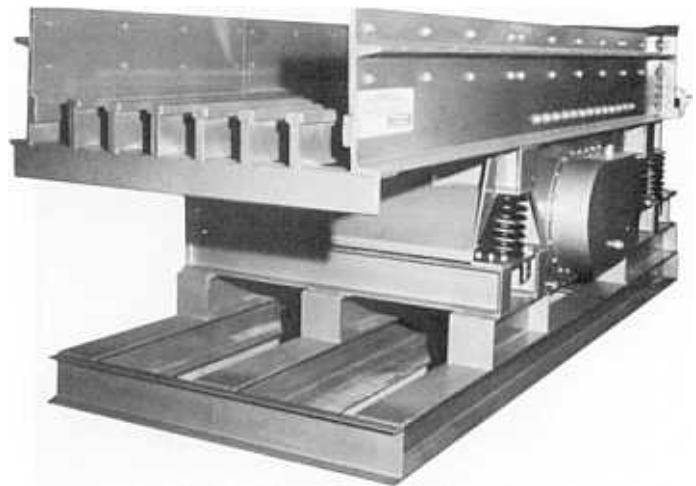

The vibrating feeder is a special case of the straight-line horizontal vibrating screen. Shown with a tapered T-bar grizzly deck for scalping ahead of primary or secondary crushers, the vibrator unit is underslung beneath the feeder pan. This inertia-driven, self-balancing feeder is practical in lengths up to 16 ft. Aptly named "brute force", this design has more resistance to stalling under load than the tuned natural frequency or "two-mass" feeders it can replace. Because amplitude is constant at all frequencies, feed rate can be precisely regulated through a variable-frequency inverter in the motor power supply.

## OTHER OPTIONAL ACCESSORIES

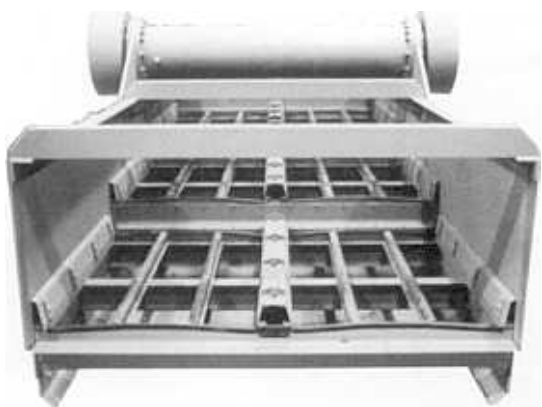

An OHV screen box designed for wet service with three-step split deck with repulping troughs, or "wash pockets", and longitudinal divider arranged for the installation of two parallel fine-mesh screen cloths in each stepped panel. This design offers best screen life and performance in fine-mesh screening on decks wider than about 5 ft.

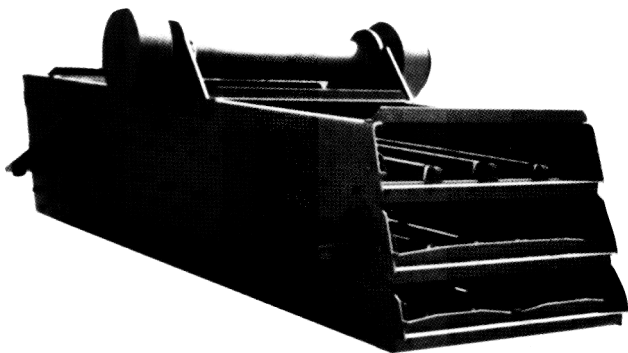

A 6 ft. wide OHV inclined screen box with first and second deck single-crowned. The bottom deck is double-crowned with a center hold-down for reducing crown height and improving performance in moderately fine-mesh screening.

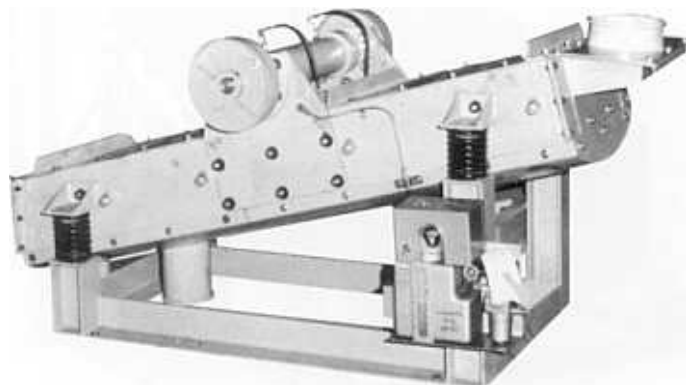

Oil-mist lubrication protects bearings in an OHV inclined screen designed for a high "g" operation in a dusty environment.

Feed boxes, hoppers and chutes are not included with the basic unit, but may be provided in any desired combination and discharge arrangement. Feed boxes and cover lids in most cases are integral with the screen box, but oversize and fines hoppers may be either integral or stationary, the latter supported from the base frame. Welded or bolted wear liners can be specified to protect the surfaces of the feed pan, side plates, collecting hoppers, and chutes from impact and abrasion.

Single-crown deck construction without center hold-down, affording easy screen cloth changing on all decks, is standard in 4-foot screen widths. For 5 and 6-foot wide machines, the customer may specify the same single-crown construction, or single-crown with centerline hold-down, or double-crown. The two latter styles require successively less crown, improving material distribution in the smaller aperture ranges. This improvement is obtained at the price of somewhat greater difficulty in cloth changing, especially in lower decks of multiple-deck screens. Factory recommendations will take into account both factors against specific job requirements.

Either oil-mist or circulating oil systems can be furnished with any vibrator unit, if desired. The oil-mist system, lower in cost than circulating oil, offers good protection against reduced bearing life due to contamination in dusty or corrosive environments. The circulating oil system, with filter and optional cooler, further adds to this advantage an enhanced ability to dissipate heat in installations handling hot materials or subjected to elevated ambient temperatures. The oil-mist system requires a source of compressed air, while the circulating oil system does not. Either system can include heaters to insure oil flow when starting at low temperature extremes.

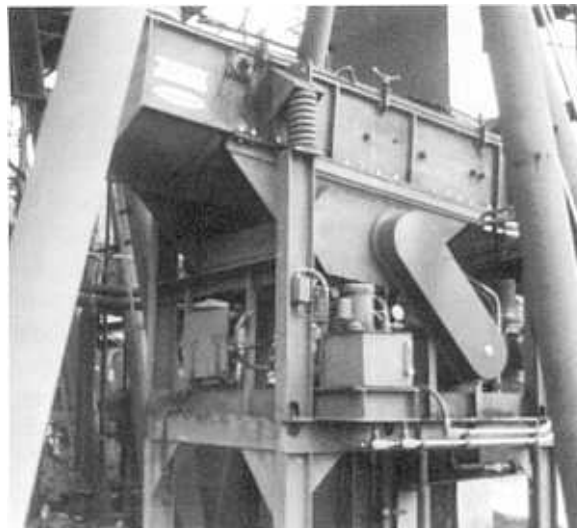

A straight-line horizontal screen removing flyash from a circulating filter media at temperatures above 1000°F. Bearings are protected with a circulating oil system with oil cooler.

# **SCREENING STRATEGIES™**

by Triple/S Dynamics

**Serves the Processing Industries World-Wide**



**Screening Strategies**  
By Triple/S Dynamics

**1031 S. Haskell Ave.**

**Dallas, TX 75223**

**Phone: 214-828-8600**

**Fax: 214-828-8653**

**E-mail: [sales@screen-tek.com](mailto:sales@screen-tek.com)**

**Website: [www.sssdynamics.com](http://www.sssdynamics.com)**

**Overstrom® High Speed  
Vibrating Screen**

By Screening Strategies™  
A division of Triple/S Dynamics 1031 S. Haskell Dallas, TX 75223